

HOW MUCH IS YOUR DUST WORTH?

Resistant and ready for anything!

The VF1000E central vacuum cleaner: designed for high and sustained production. Ideal for covering the cleaning of large spaces and large quantities of material. Robust and reliable, it will never let you down!

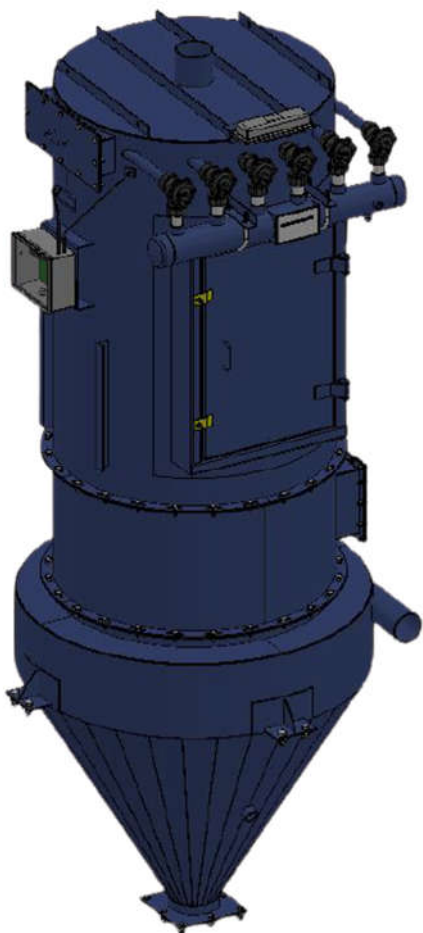

Vacuum Central Filtrartech VF1000E

- Flow: 1000 cfm
- Ratio: 1.45 ft / min
- Filtration area: 897 ft²
- Cleaning by pulsed jets
- Filtration cartridges
- 50 Hp @ 600V tri-lob pump
- CSA certified electrical panel c / a starter,
- High level probe for unit shutdown
- Safety valve at the inlet of the pump

Option: Other flow capacities available.

DIMENSIONS

Diameter : 62''

Height : 139''

